



T-55 HAND BAR & TUBE PRINTER

PRINTING



Simple, economical printing on bar & tube.

The T-55 is a lightweight, hand-operated, friction-driven printer designed for marking 1/4" diameter or larger products like bar, tube, and structural shapes. Rolling along the material, the T-55 clearly imprints date codes, logos, customer names, and other information with ease. The rubber friction roll ensures sharp, smudge-free printing by rotating the print wheel at the same speed the printer is traveling. The grooved guide rolls allow printing on a wide variety of material sizes.

This printer can be used alone or in combination with Pannier in-line printers when you need supplemental or lot identification information. It is ideal for applications requiring variable filler information or for re-marking small runs.

The T-55 Hand Bar & Tube Printer serves a wide range of code marking requirements. A printed legend up to 12" (305mm) long can be set in the printer using Pannier E-Z Set rubber dies. Dies – either single characters or multi-character logotypes – are available in a standard font or can be custom-made according to your supplied artwork. The print wheel must contain a complete 12" of type to operate properly. If your printed message is shorter than 12", a strip of dashes inserted in free areas completes the wheel.

To create a printed message, rubber dies are pressed into the center groove of the E-Z Set print wheel. The characters on the dies range from 1/16" (1.58mm) to 3/4" (19mm) tall. For special printing applications, other print wheels may be required. Ask your Pannier representative for specific recommendations for your particular printing requirements.

The ink fountain is made of foam rubber. Each ink fountain is stored in its own plastic container. Soaking the fountain in ink in the container prepares it for printing and ensures even distribution of ink. When not printing, the fountain can be removed from the printer and placed back in its container. Having several ink fountains on hand allows for easy color changes.

INK & DIES

Pannier is your single-source supplier for printers, mounting accessories, printing dies, and a wide variety of industrial inks.



Pannier offers a wide variety of industrial printing inks. Each ink and companion solvent is specially formulated for best performance in common industrial applications.

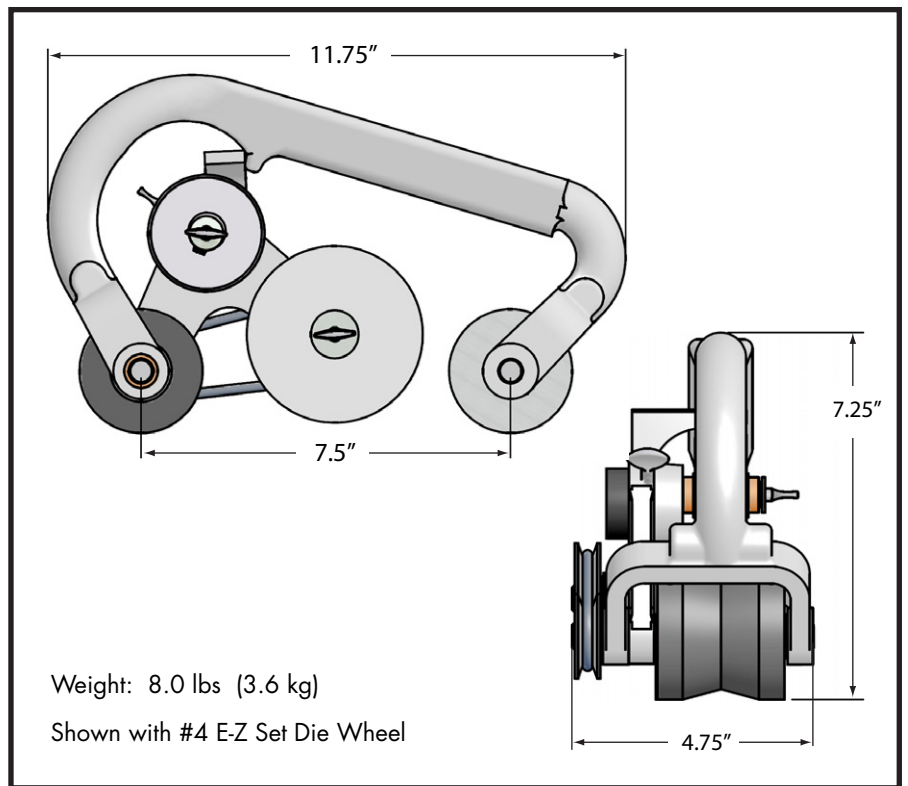

Physical dimensions of the T-55 Hand Bar & Tube Printer

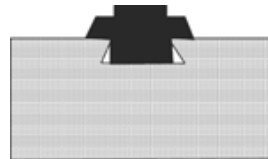

E-Z Set Dies

Simple printing dies are held in center slot for single- or multiple-line printing.



The characters on the dies range from 1/16" (1.58mm) to 3/4" (19mm) tall. Special characters or logos can be made according to your supplied artwork.

PANNIER CORPORATION

207 Sandusky Street • Pittsburgh PA 15212-5823 USA

412-323-4900 tel • 412-323-4962 fax • sales@pannier.com • www.pannier.com