



# ADP120160 STAMPER

INDENTING



## A revolution in dot peen marking.

The ADP120160 dot peen marking system combines quality, precision marking with fast and easy programming. Operate in dot peen or vibropeen marking mode with your choice of marking pin for multiple marking tasks. The ADP120160 marking head, with a marking window of 120mm x 160mm, can be used for in-line, benchtop, or portable marking with a variety of accessories.

The revolutionary AC500 controller features a 7" color touchscreen with easy, intuitive software that can also be run on a PC. The serial, I/O, Ethernet, and USB ports offer maximum flexibility for connecting to a PC or host computer, PLC, bar code scanner, and other devices. Built-in security protects your settings and marking patterns from unintended changes.

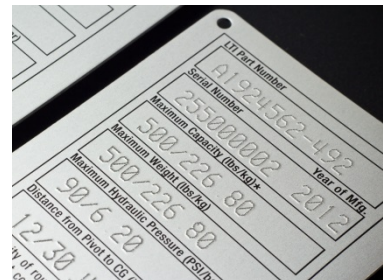

## SPECIFICATIONS

Marking Window	120mm x 160mm (4.7" x 6.3")
Marking Head	260mm W x 220mm D x 123mm H (10.2" x 8.7" x 4.8") Rated IP40, 16.5 lbs (7.5 Kg)
Controller	230mm W x 191mm D x 110mm H (9" x 7.5" x 4.3") Rated IP40 (tabletop)/IP61 (wall mounted), 5 lbs (2.3 Kg)
Interface	RS-232/RS-485, Ethernet TCP/IP, I/O, and USB
Memory	64 MB internal memory
Input/Output	12 programmable input signals (6 dedicated) 6 programmable output signals (2 dedicated)
Electric Supply	90-250 VAC / 50-60 Hz
Air Supply	60-90 PSI, clean and dry
Operating Environment	Humidity: 10 – 80% non-condensing Temperature: 32°F – 122°F
Languages	English, French, Spanish (others available)
Fonts	Standard: 5x7, 11x16, OCR, 11x16 CH, AHSA, 2D Data Matrix and QR codes. Load and mark any TrueType font.

## EASY PROGRAMMING WITH THE AC500 CONTROLLER

Create marking patterns step-by-step with fields containing text, lines, shapes, serial numbers, date/time codes, shift codes, .bmp and .dxf files, and 2D codes. Patterns can also use variable data entered by the operator, retrieved from a lookup table, or obtained from a bar code scanner, host computer, or other external device.

The preview screen shows how your pattern will look when it's marked – click and drag fields to move and resize them for precise placement. Once your pattern is complete, use the Check Area and Dry Run options to ensure that the entire message fits within the marking area and to watch the stylus move through the entire pattern without actually marking on the part.

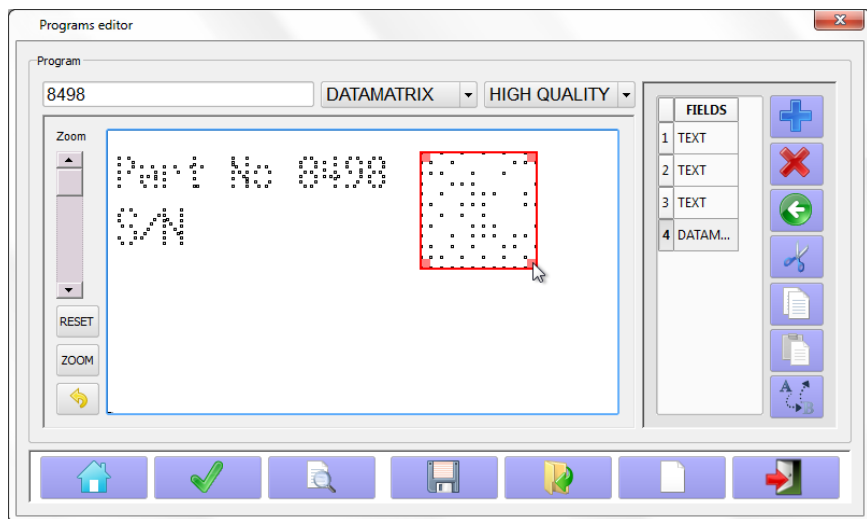

## OPTIONS

- 3mm or 6mm dot peen pins, 3mm vibropeen pin
- mounting column and base for benchtop marking
- two-handled portable marking fixture
- rotary marking fixture for marking cylindrical parts
- remote start/stop buttons or foot pedal

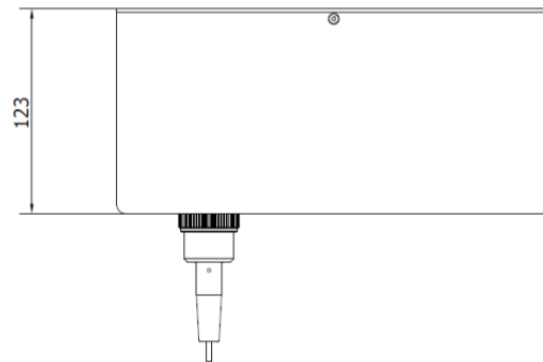
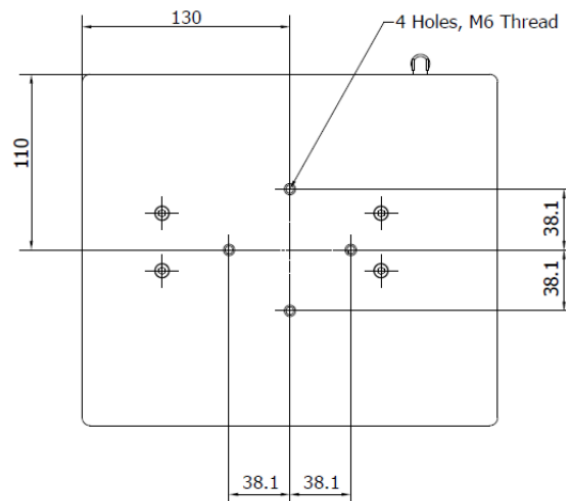
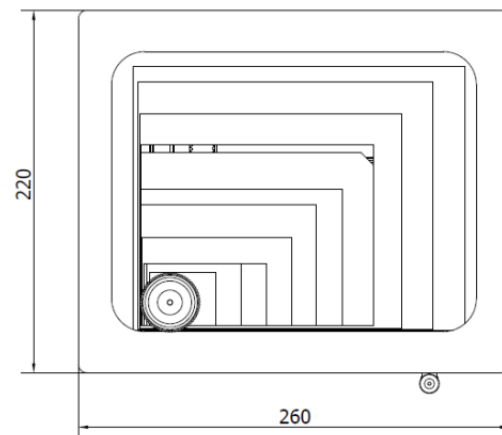

## PANNIER CORPORATION

207 Sandusky Street • Pittsburgh PA 15212-5823 USA  
412-323-4900 tel • 412-323-4962 fax • sales@pannier.com • www.pannier.com